

ANA

Breakers & Demolition Attachments



ANA ENGINEERING CO., LTD.

ADD. Daecheong Apt. 303-1004
Gaepo-dong, Gangnam-gu
Seoul, 135-940, Korea

TEL. +82-10-7186-1990
E-mail. anaahn@hanmail.net
anabreakers@gmail.com





ANA Silenced Box Type



ANA Silenced Box Type INWARD & OUTWARD SYSTEM

- Reduced noise emission and improved vibration damping system.
- Slim profile with robust structure.
- Fully enclosed robust housing.

Compact Range		INWARD SYSTEM (Hydraulic & High Gas)					
Description	Unit	AB20S	AB30S	AB30SSL	AB35S	AB40S	AB43S
Operation Weight	kg	120	140	140	210	320	395
	lb	265	308	308	462	705	871
Carrier Weight	ton	1.2-3.0	2.5-4.5	2.5-4.5	3.0-5.5	4.0-7.0	6-9
Required Oil Flow	l/min	20-40	25-50	25-50	30-60	40-70	50-90
	gal/min	5-10.5	6.5-13	6.5-13	8-16	10.5-18.5	13-24
Operating Pressure	bar	90-120	90-120	90-120	100-130	110-140	120-150
	psi	1305-1740	1280-1707	1280-1707	1450-1885	1595-2031	1740-2134
Impact Rate	bpm	700-1200	600-1100	600-1100	500-1000	500-900	400-800
Tool diameter	mm	45	53	53	60	68	75
	inch	1.811	2.087	2.087	2.362	2.677	2.953

Midium Range		INWARD SYSTEM (Hydraulic & High Gas)				
Description	Unit	AB45S	AB50S	AB60S	AB70S	AB81S
Operation Weight	kg	600	920	1460	1705	1816
	lb	1323	2028	3219	3759	4004
Carrier Weight	ton	7-14	11-16	15-18	18-21	18-26
Required Oil Flow	l/min	60-100	80-110	90-120	100-150	120-180
	gal/min	16-26	21-29	24-32	27-40	32-48
Operating Pressure	bar	130-160	150-170	150-170	160-180	160-180
	psi	1849-2321	2134-2418	2134-2418	2276-2560	2276-2560
Impact Rate	bpm	400-800	350-700	350-650	350-600	350-500
Tool diameter	mm	85	100	125	135	140
	inch	3.346	3.937	4.921	5.315	5.511

Heavy-Duty Range		INWARD SYSTEM (Hydraulic & High Gas)					OUTWARD SYSTEM		
Description	Unit	AB100S	AB121S	AB130S	AB151S	AB186S	AB20GS	AB30GS	AB40GS
Operation Weight	kg	2290	2890	3140	4075	1310	1840	2540	3100
	lb	5049	6371	6923	8984	2888	4056	5600	6834
Carrier Weight	ton	25-30	28-35	30-45	40-55	13-18	18-26	27-35	35-50
Required Oil Flow	l/min	150-210	180-240	200-260	210-290	90-120	130-150	150-190	190-250
	gal/min	40-56	48-63	53-69	55-77	24-32	34-40	40-77	77-65
Operating Pressure	bar	160-180	160-180	160-180	160-180	160-180	160-180	160-180	160-180
	psi	2276-2560	2276-2560	2276-2560	2276-2560	2276-2560	2276-2560	2276-2560	2276-2560
Impact Rate	bpm	300-450	300-450	250-400	200-350	350-850	400-500	300-450	250-400
Tool diameter	mm	150	155	165	175	120	135	150	160
	inch	5.905	6.102	6.496	6.889	4.724	5.315	5.905	6.299

• "S" : Silence • "SSL" : Silenced skid loader



ANA Top Type



ANA Top Type INWARD & OUTWARD SYSTEM

- Most simple and cost-effective solution to your breaking needs

		INWARD SYSTEM (Hydraulic & High Gas)					
Compact Range		AB20T	AB30T	AB30TSL	AB35T	AB40T	AB43T
Description	Unit						
Operation Weight	kg	100	120	160	190	298	375
	lb	220	265	353	419	657	827
Carrier Weight	ton	1.2-3	2.5-4.5	2.5-4.5	3.0-5.5	4.0-7.0	6-9
Required Oil Flow	l/min	20-40	25-50	25-50	30-60	40-70	50-90
	gal/min	5-10.5	6.5-13	6.5-13	8-16	10.5-18.5	13-24
Operating Pressure	bar	90-120	90-120	90-120	100-130	110-140	120-150
	psi	1280-1707	1280-1707	1280-1707	1422-1849	1565-1991	1707-2134
Impact Rate	bpm	700-1200	600-1100	600-1100	500-1000	500-900	400-800
Tool diameter	mm	45	53	53	60	68	75
	inch	1.57	2.087	2.087	2.362	2.677	2.953

		INWARD SYSTEM (Hydraulic & High Gas)				
Midium Range		AB45T	AB50T	AB60T	AB70T	AB81T
Description	Unit					
Operation Weight	kg	577	890	1431	1675	1786
	lb	1272	1962	3155	3693	4023
Carrier Weight	ton	7-14	11-16	15-18	18-21	18-26
Required Oil Flow	l/min	60-100	80-110	90-120	100-150	120-180
	gal/min	16-16.5	21-29	24-32	27-40	32-48
Operating Pressure	bar	130-160	150-170	150-170	160-180	160-180
	psi	1849-2276	2134-2418	2134-2418	2276-2560	2276-2560
Impact Rate	bpm	400-800	350-700	350-650	350-600	350-500
Tool diameter	mm	85	100	125	135	140
	inch	3.346	3.937	4.921	5.315	5.511

		INWARD SYSTEM (Hydraulic & High Gas)					OUTWARD SYSTEM		
Heavy-Duty Range		AB100T	AB121T	AB130T	AB151T	AB18GT	AB20GT	AB30GT	AB40GT
Description	Unit								
Operation Weight	kg	2237	2838	3065	4002	1230	1740	2420	3020
	lb	4620	5940	6589	9020	2706	3828	5324	6644
Carrier Weight	ton	25-30	28-35	30-45	40-55	13-18	18-26	27-30	35-50
Required Oil Flow	l/min	150-210	180-240	200-260	210-290	90-120	130-150	150-190	190-250
	gal/min	40-56	48-63	51-69	55-77	24-32	34-40	40-77	77-65
Operating Pressure	bar	160-180	160-180	160-180	160-180	160-180	160-180	160-180	160-180
	psi	2276-2560	2276-2560	2276-2560	2276-2560	2276-2560	2276-2560	2276-2560	2276-2560
Impact Rate	bpm	300-450	300-450	250-400	200-350	350-850	400-500	300-450	250-400
Tool diameter	mm	150	155	165	175	120	135	150	160
	inch	5.905	6.102	6.496	6.889	4.724	5.315	5.905	6.299

• "T" : Top Type • "TSL" : Top Type skid loader

ANA

Breakers Features

Inward System

Models : AB20, AB30, AB35, AB40, AB43, AB45, AB50, AB60, AB70, AB81, AB100, AB121, AB130, AB151

- Fewer Components - Less maintenance.
- Highest power by high density of accumulated gas.

Outward System

Models : AB18G, AB20G, AB30G, AB40G

- Easier maintenance.
- Reduces strain on the breaker and the carrier.
- Stable system & compatible parts with other brands.

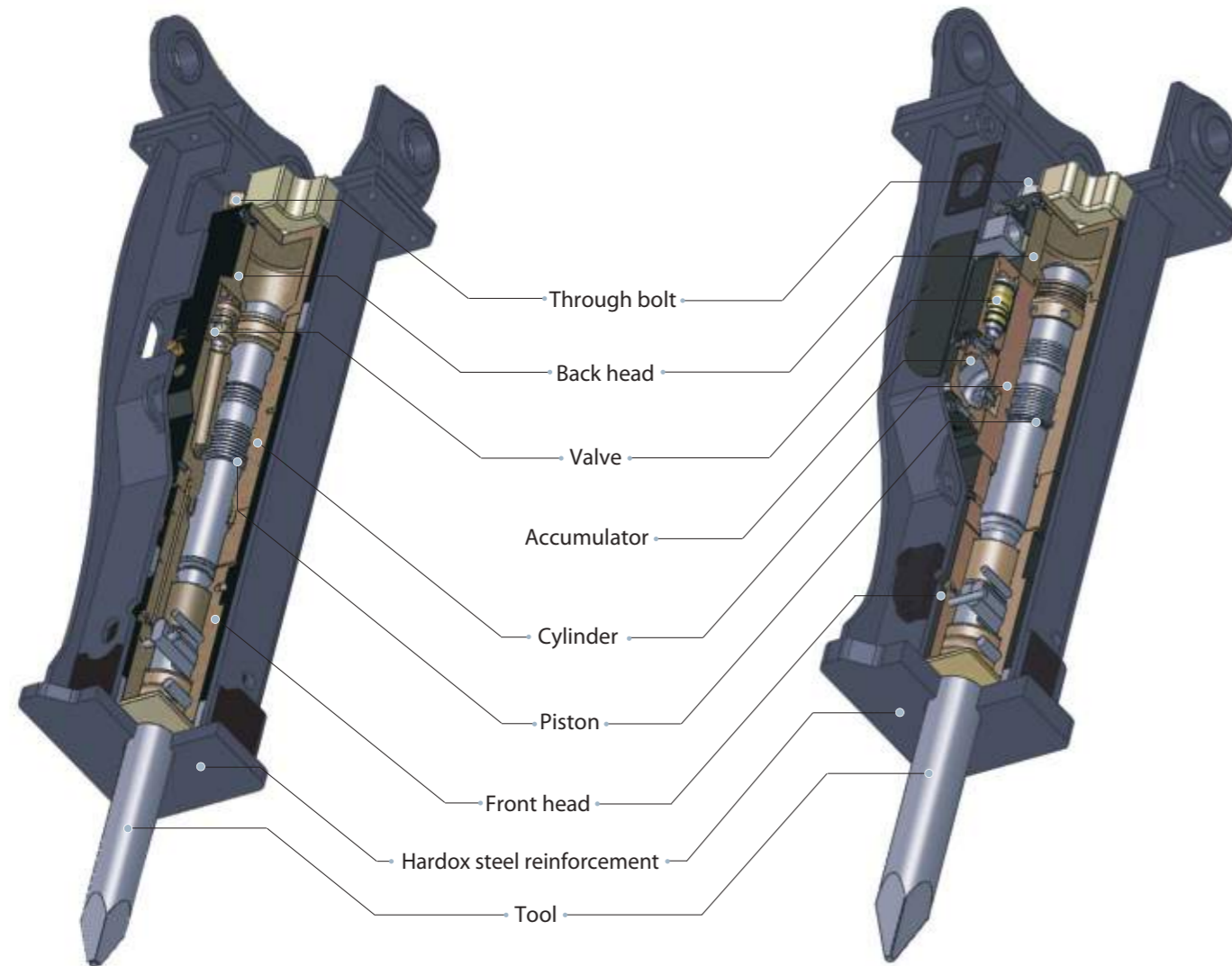

ANA

Spare Parts



In-house production and heat treatment

Allows continuous technical developments, maintain homogenizing quality level.

Full Manufacture Warranty

All breakers are backed by ANA's standard factory warranty.

Genuine ANA parts and tools

Ensure optimum precision, durability and working life.

Rod Types

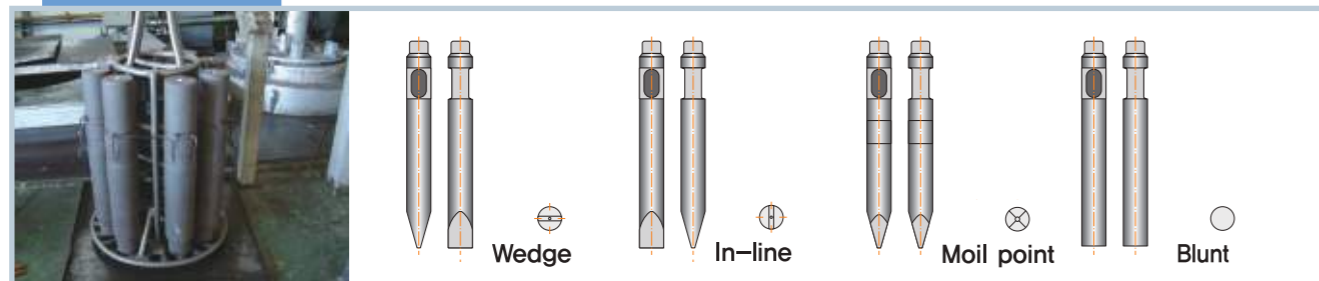

ANA Attachments

CRUSHER

Primary & secondary demolition



ORANGE GRAPPLE



PULVERIZER

FSM Series

Secondary demolition and recycling of concrete



DEMOLITION GRAP

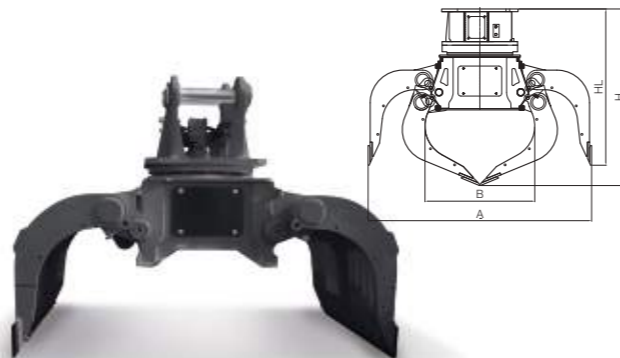

MULTI CRUSHER

RSM Series

Primary & secondary demolition



STONE GRAPPLE



SHEAR

RSM Series

Primary & secondary demolition



WOOD GRAPPLE



ANA Attachments

CLAMSHELL



QUICK COUPLER



COMPACTOR



RIPPER



ANA ENGINEERING LINE-UP

Hydraulic Breakers

- Silenced Box Type
- Top Type

Attachments

- Crusher
- Pulverizer
- MC - Multi Crusher
- Shear
- Orange Grapple
- Demolition Grap
- Stone Grapple
- Wood Grapple
- Clamshell
- Compactor
- Quick Coupler
- Ripper



ANA

Applicable machines for ANA Breakers

ITEM/Model	BOBCAT	CASE	CASE/POCLAIN	CAT	DOOSAN	HITACHI	JCB	KOBELCO	KOMATSU	LIEBHERR	HYUNDAI	Q&K	VOLVO
AB 20 (1.2-3.0 Tons)	709, 8709, 4408,	CK1.3, CK15,	CK08, CK13,	301-5, 303-6,	SOLAR007,	EX8, UE10, EX12,	801, 8015,	SK007, SK09,	PC05, PC07-2		ROBEX35	RH1.1, RH1.2,	EC14, EC15B
	443, X119, X120,	CK161, 825, 835B,	CK15, CK25	301-8	SOLAR0010	UX12, UE15, EX17,	8016	SK013, SK13				RH1.17, RH1.21	EC20B
	81, 463, 322D,	1818, 1830				EX18, UE20, EX22							
	533F												
AB 30 (2.5-4.5 Tons)	B100, B200, B250,	CK23, CK28, CK31,	CK23, CK28,	302-5, 303-5,	DH30,	EX25, EX38,	1CX, ROBOT	SK015, SK15,	PC10, PC12,		HX15SR	RH1.29, RH1.3,	EC30, EC25,
	520, 533F, 543, 630,	40XT, 60XT, 1830	CK31, 40XT,	216, 226, 228	SOLAR30,	EX30, UE30,	150/160/165/	SK16, SK25	PC15, PC20,			RH1.35	ZL302C
	631, 641, 643, 645,		60XT, 1830		SOLAR035,	EX33	165/170/185		PC27				
	721, 753, 763, 773,				DSL602								
AB 35 (3-5.5 Tons)	X122, X123, X220,												
	X225, X825, X320,												
	X325, 325D, 328D,												
	S175, S185												
AB 40 (4-7 Tons)	883, 963, 943, 980,	840, 1845, CX35,	CK36	303CR, 304-5,	DSL702,	EX34, EX40, UE40	ROBOT190	SK025, SK030,	PC30, PW30,		ROBEX450,	L4A, RH1.48,	EC35, EC45
	T300, 337D, 331(E),	70XT, 75XT, 85XT		232, 236, 242,	DSL802			SK035, SK30,	PE35		ROBEX500,	RH2.4	
	A220(S), T200(S),			246, 248, 262				SK35			ROBEX500W		
	341D, 442D, X335												
AB 43 (6-9 Tons)		90XT, 95XT, CX50,	CK36CK50, CK62,	416, 420, 426, 428,	DH50, SOLAR50,	EX40U, EX45,	2CX, 3C/CX/D, ZL	SK045, SK050,	PC40, PC45,	L506/507/508/	ROBEX95W	MH2.5, RH2.5,	EC55, EC70,
		550, 580, 590,	488C	430, 438, E70B,	SOLAR555/55V,	EX50, UE50(e),	70, ROBOT1105/	SK45, SK60, SK70,	PC50, PC60,	509/512/514		MH2.8, RH2.8	EW50, EW70,
		680CK, CK62		5080, 252, 262,	SOLAR70, DSL902	EX58, EX60, UH02	1110, 407/408/	SK80, SK600,	PC75, PW75,				L20B/25B/30B/
				304CR, 305CR, 307			409/410ZX	K903	PC80, PC90				
AB 45 (7-14 Tons)		WX90, 965, CX75,	FC30, FY30, 488P	446B, 307,	SOLAR80,	UH04, UH043,	4CX, 416HT	SK60MX	PW95	A308	ROBEX110-V11	MH3, RH3,	BL74, L50D,
		621D	FC30, FY30	308, 931	DH80W	EX80, EX90,		III, K904,				MH2.10, RH2.10	612, 616B
						ZAXIS80		80CS, SK100					
AB 50 (11-16 Tons)		WX120, CX130,	CK60, CK61, 688	E110B, 205, 206,	DH130, SOLAR130	EX100, EX110, EX120,	JS130, JS145, 805,	SK115, SK120,	PC100, PW110,	A/R902, R900,	HX60W,	MH3.5, RH4,	EC130, EW130,
		CX135, 588P, 788F,		311, 312, 314, 515,		EX130, EX135, UH051,	811, 812, 814,	SK135, SK150,	PC120, PC128,	A/R901, R308,	ROBEX130W,	MH4, MH4.5	SE130, SE130W
		880, 888, 9010,		206BFT, 212BFT		UH053, UH061,	5C/W	K120, K150, K904,	PC130, PW130	A310, A312,	ROBEX35140LC		EW140, 646,
		9020				UH063, ZAXIS120		K905		A314			L60E, L70E
AB 60 (15-18 Tons)		WX150, CX160,	70CK, 80CK, 8CK	214B, E120B, 315,	SOLAR170, DH170		JS150, JS160,	SK135, SK160	PC150, PW150,	A/R902, A/R900,	ROBEX170W,	RH4.5, RH5, MH5	EC140B, EC150,
		788RR, 1085	888	525B, 535B			JS175	K150	PW170	R310, R312,	ROBEX180LC		EW150, EW160,
										A316			L90E
AB 70 AB 81 (18-26 Tons)		CX180, CX210, CX225,	85CK, 90CK,	215, 219, 224, 225,	DH200,	EX200, EX210, EX220,	JS180, JS200,	SK270LC, SK290,	PC180, PC200,	A/R904, R912,	HW80,	MH5.5, RH5.5,	EC200, EC210,
		CX240, WX170,	115PC,	318, 320, 321, 322,	SOLAR200,	EX225, EX230, H801/	JS210, JS220,	SK300, SK320,	PC210, PC220,	A/R914, A/R921,	ROBEX200W,	MH6, RH6,	EC230, EC240
		WX220, CX188FG,	125CK, 1088,	E/EL180, E/EL220,	DH220, SOLAR220	803, UH09(e), UH073,	JS240, 7B/C, 8C/D	K300, K912	PC228, PC230,	A/R922, A924,	ROBEX200LC,	MH6.5, RH6.5,	SE210, EW230
		9030, 9040, 1080,	1188, 6988	E/EL240, 517, 527,		UH103, ZAXIS200,			PC240	A/R932, R941	ROBEX220LC,	RH8	
AB 100 AB 121 (25-35 Tons)		9045B, CX240,	1288, SC150L,	229, 325, E/EL300,	DH280, DH320,	ES270, EX280,	JS330	SK270LC, SK290,	PC250, PC280,	A/R942LIT,	HX100,	RH8.5, RH9,	EC280, EC290,
		CX290, CX1288,	RC200, 160CK/CL,	229D, 231, 330	SOLAR280, SOLAR	UH121, UH123,		SK300, SK320,	PC300, PC350	A/R934, R924,	ROBEX280LC/	RH9.5, RH11,	EC300, SE280,
		6050, 9050B,	170CK-B		290, SOLAR320,	UH143EX300,		K300, K912		R932LIT	290LC/300LC/320	RH12, RH14	SE350
		CX330			SOLAR330	EX350, ZAXIS270,					LC/330LC/360LC		
AB 130 (30-45 Tons)		CX350, CX460,	22CK/CL, 220CKB	235, 330BL/CL,	SOLAR360, SOLAR	EX370, EX400,	JS460	SK330, SK400,	PC360, PC400,	R944, R952,	ROBEX360LC,	RH160, RH16.5,	EC340, EC360,
		CX1288FG, 170C,		345BL	400, SOLAR450,	EX450, UH171,		SK480, K400,	PC450	R954,	ROBEX420LC,	RH18, RH20,	EC390, EC420,
		2200B, 9060			SOLAR470, DH450	UH181		K914, K916		R961, R962	ROBEX250LC	RH25	EC450, EC460
AB 151 (40-55 Tons)			300CK	50ME, 245, 345,		UH120, UH20, EX550,		SK600	PC600, PC650,	A944, R962LIT,	ROBEX500LC	RH23, RH25.5	EC620, EC650
				350, 365		EX600, EX700			PC750	R964, R974		RH30D	

ANA

DTH Hammers & Bits / Rock Tools

